

SiroLock[®]

The next step in fibre control

Contents

1. **What is SiroLock®?**
2. **How is SiroLock® working?**
3. **Benefits of the SiroLock® wire**
4. **SiroLock® wire types**
5. **Industry related value of SiroLock® wire**
6. **Conclusion**

1. What is SiroLock®?



The inventor of SiroLock®, Ken Atkinson of CSIRO*:

“SiroLock® is a totally new concept in metallic wire. The step in the wire is increasing the retention of fibres and the carding action. Industrial application of SiroLock® has shown multiple benefits and value on roller cards, in worsted, woollen as well as in nonwoven applications”

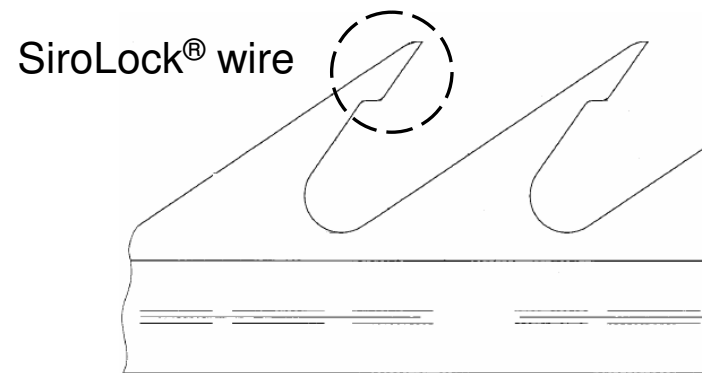

- SiroLock® is protected by patents and copyright
- Especially designed for doffers and workers
- Bekaert has an exclusive license to manufacture and market the SiroLock® wire

 **BEKAERT**

better together

2. How is SiroLock® working?

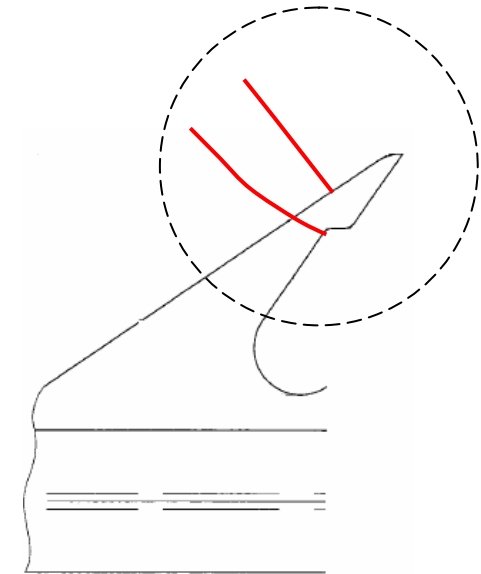
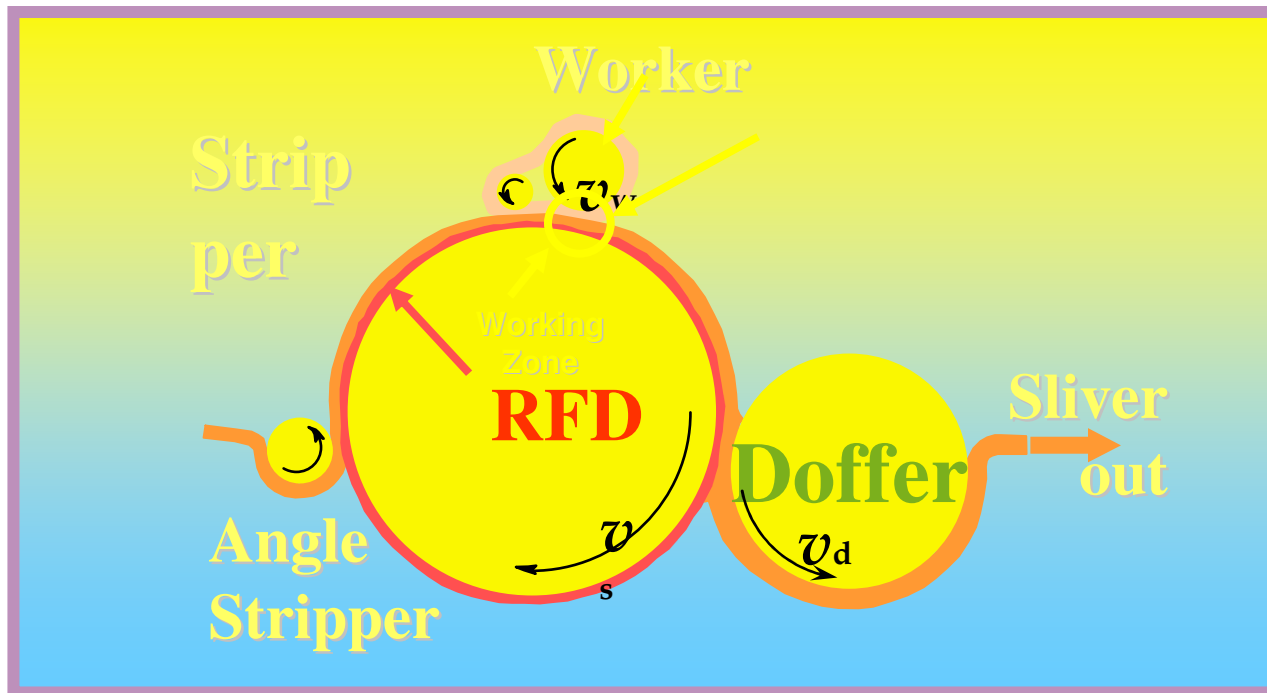

- Transfer coefficient in carding - only a certain percentage of fibres is transferred
 - From cylinder to worker
 - From cylinder to doffer
- SiroLock® increases the coefficient of transfer compared to conventional card wire
 - fibres are controlled and held under the step

2. How is SiroLock® working?

Higher fibre transfer coefficient:

SiroLock® wire can catch up to 40-50% more fibres

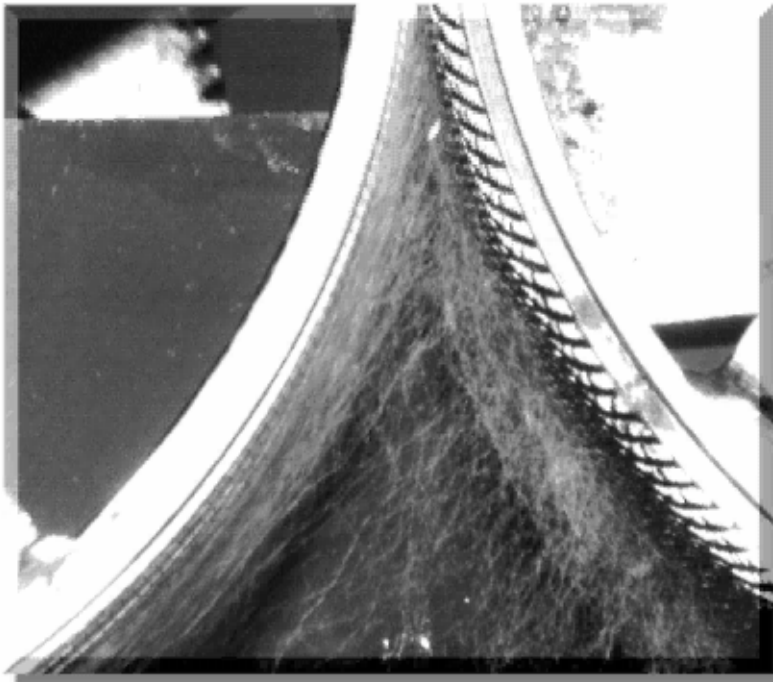

SiroLock®

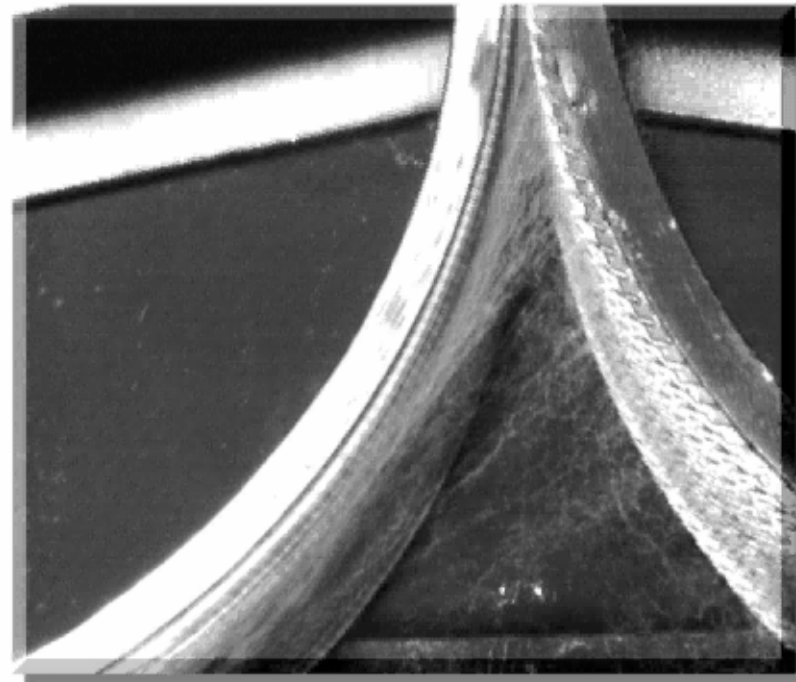

Conventional wire

2. How is SiroLock® working?

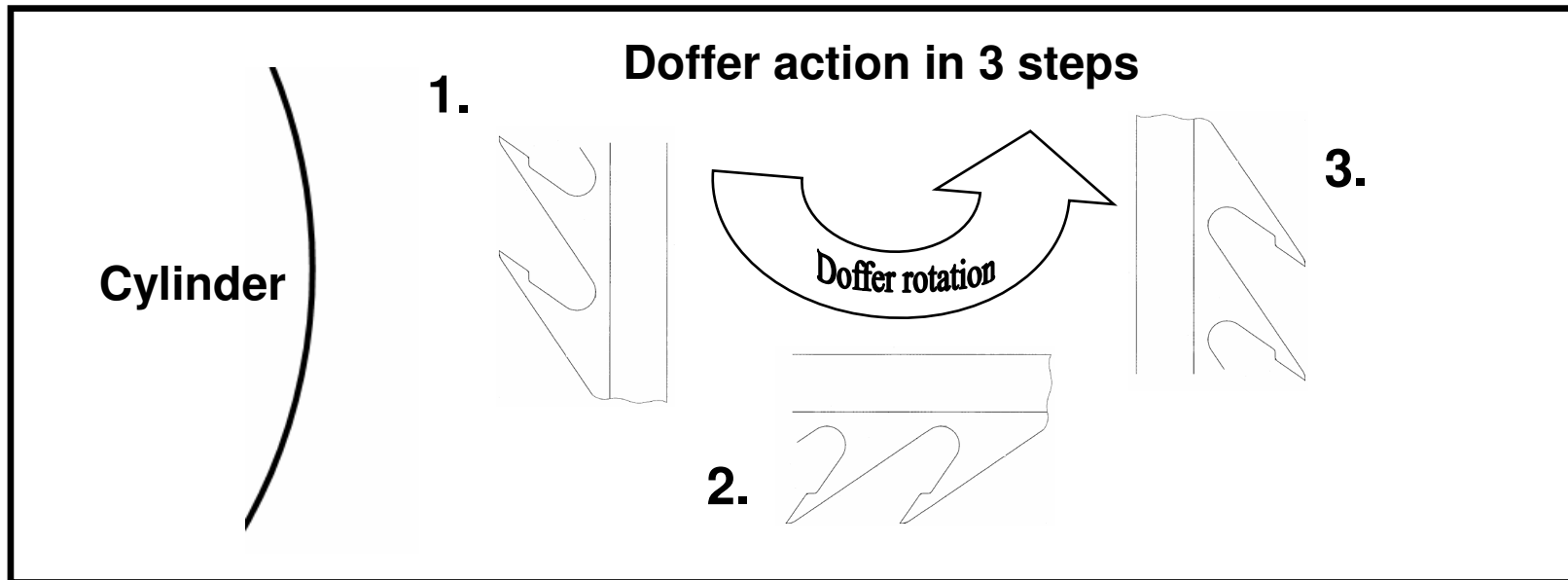

1. On doffers and workers
 - The fibres are caught and controlled by the SiroLock® wire
 - More fibres are transferred compared to conventional wire
2. The fibres are well controlled by the step and no longer by the front angle of conventional wire. No striations are required.
3. The fibres can easily be stripped away as the fibres are moved to the back angle of the previous tooth

3. Benefits of SiroLock® wire

SiroLock® wire is favourable under all circumstances.

- its benefit is more important in the doffing zone for longer fibres, and more important in the carding zone for shorter fibres
- The SiroLock® worker wire will keep the fibre until deep in the nip of worker/stripper, increasing the carding surface of the worker. It will help carding the fibres.
 - SiroLock® worker wire tends to lift more fibres to the surface of the main swift wire
 - acting as a fancy roller,
 - favouring the transfer of fibres to the doffers; and
 - keeping the fibres higher and closer to the surface of the cylinder wire.

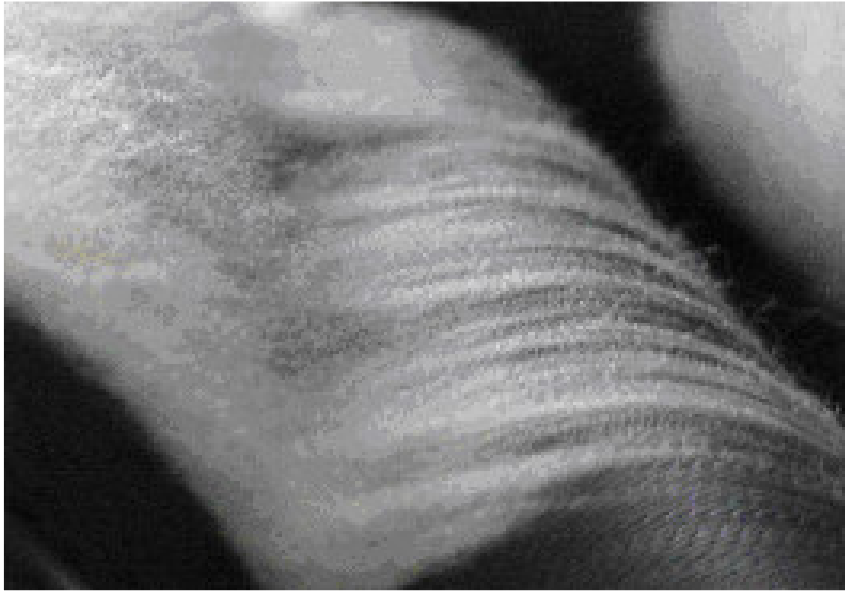

Side view of stripper and SiroLock® worker wire, compared to stripper and conventional worker wire

Fibres taken deeper into the nip.
Result : improved web uniformity

3. Benefits of SiroLock® wire

- On the worker:
 - a higher fibre transfer
 - Results in a higher carding capacity of the worker
 - More fibres can be carded at the same time, a higher throughput can be expected
 - Creates higher positioning of fibres on the cylinder wires, favouring transfer of fibres to following workers and doffers
- On to doffer:
 - a higher fibre transfer
 - higher productivity can be reached
 - less recycling
 - less risk for fibre breakage
 - and consequently less neps

3. Benefits of SiroLock® wire

- Additional benefits:
 - Thanks to the higher transfer coefficient, SiroLock® type of wire can cover a larger range of doffer and worker applications compared to the conventional wire.
 - Less critical setting of SiroLock® wire. A wider setting might compensate for a higher pick-up/transfer capacity
 - Longer wire lifetime: Less wear of the upper part of the front edge of SiroLock® wire, because fibres are kept under the step.
 - Reduced time needed to clean the swift when feeding fibres in the card is stopped (reduced sliver-decay)
 - Better fibre control on SiroLock® wire results in better web quality
 - Fibres controlled by a SiroLock® worker wire cannot be removed by the wire of a next stripper roller (long fibres)
 - Less fibre fly, due to the fibre control by the step. Also valid for slippery fibres
 - More uniform web, because more fibres are raised to the cylinder surface
 - Higher loft of the fibre web

4. SiroLock® wire types

- SiroLock® is available in five different versions covering a wide range of applications
 - L10/100 SiroLock® for the worsted industry (top making)
 - VH16/360/55 SiroLock® for heavier web nonwovens - for the breaker card
 - VH20/360/55 SiroLock® for heavier web nonwovens
 - VL24/360/55 SiroLock® for nonwoven applications
 - VF28/250/50 SiroLock® for light weight webs

4. SiroLock® wire types

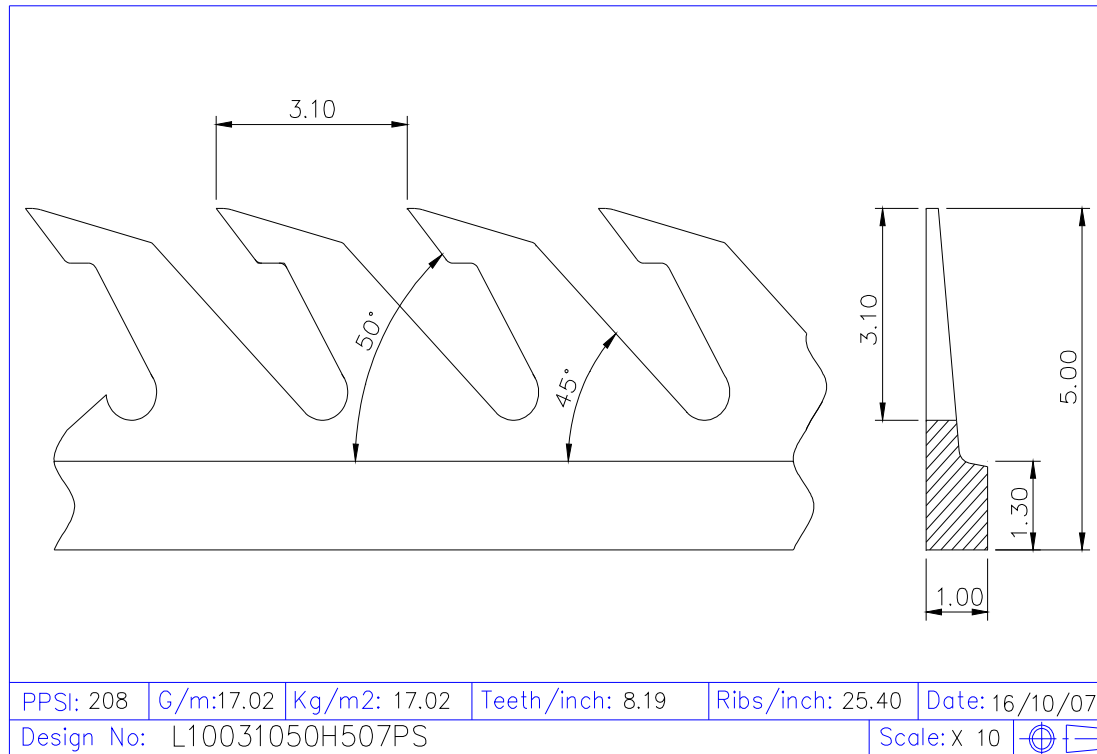

- L10/100 SiroLock® used in the worsted top making industry
- It is the SiroLock® version of the well known plain rib L10 doffer wire
 - The bottom part of the front is 60°, making it also suitable for workers on top making cards, instead of the L9s

4. SiroLock® wire types

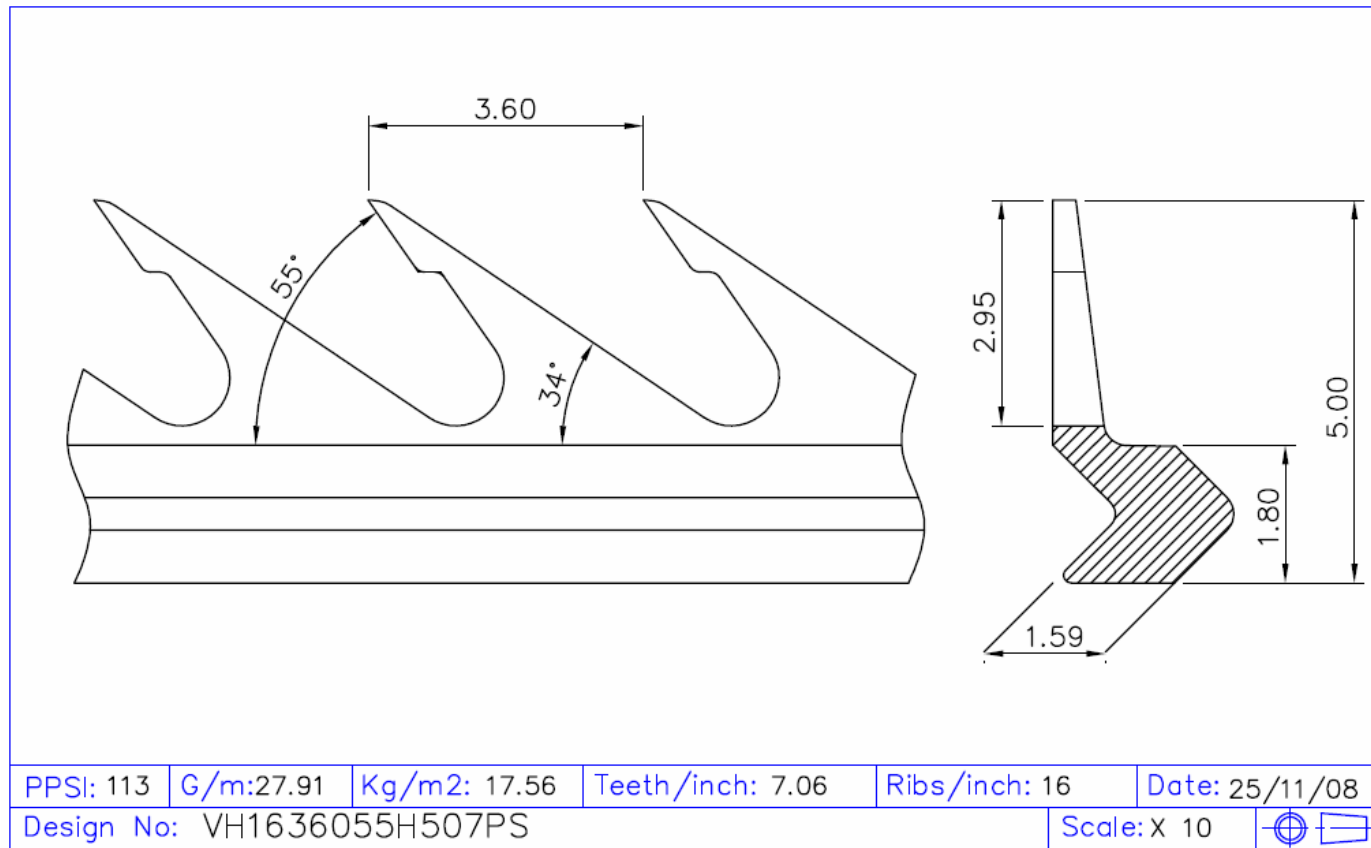

- VH16/360/55 SiroLock®
 - Used for heavier web nonwovens (wadding, needle punched carpets...)
 - Used on the breaker card

4. SiroLock® wire types

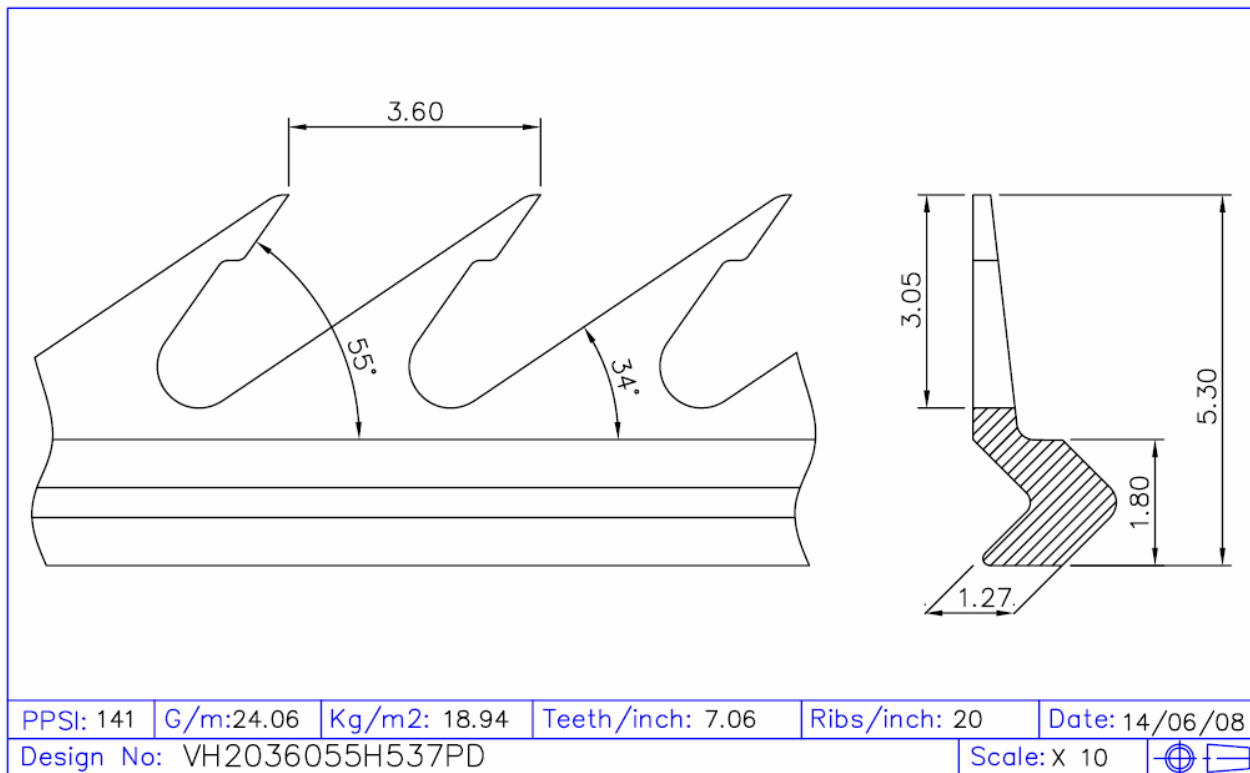

- VH20/360/55 SiroLock®
 - Used for heavier web nonwovens (wadding, needle punched carpets...)
 - and on semi-worsted cards (carpet yarns) and woollen cards
- It is the SiroLock® version of the high loft interlocking worker/doffer wire VH20/360/53

4. SiroLock® wire types

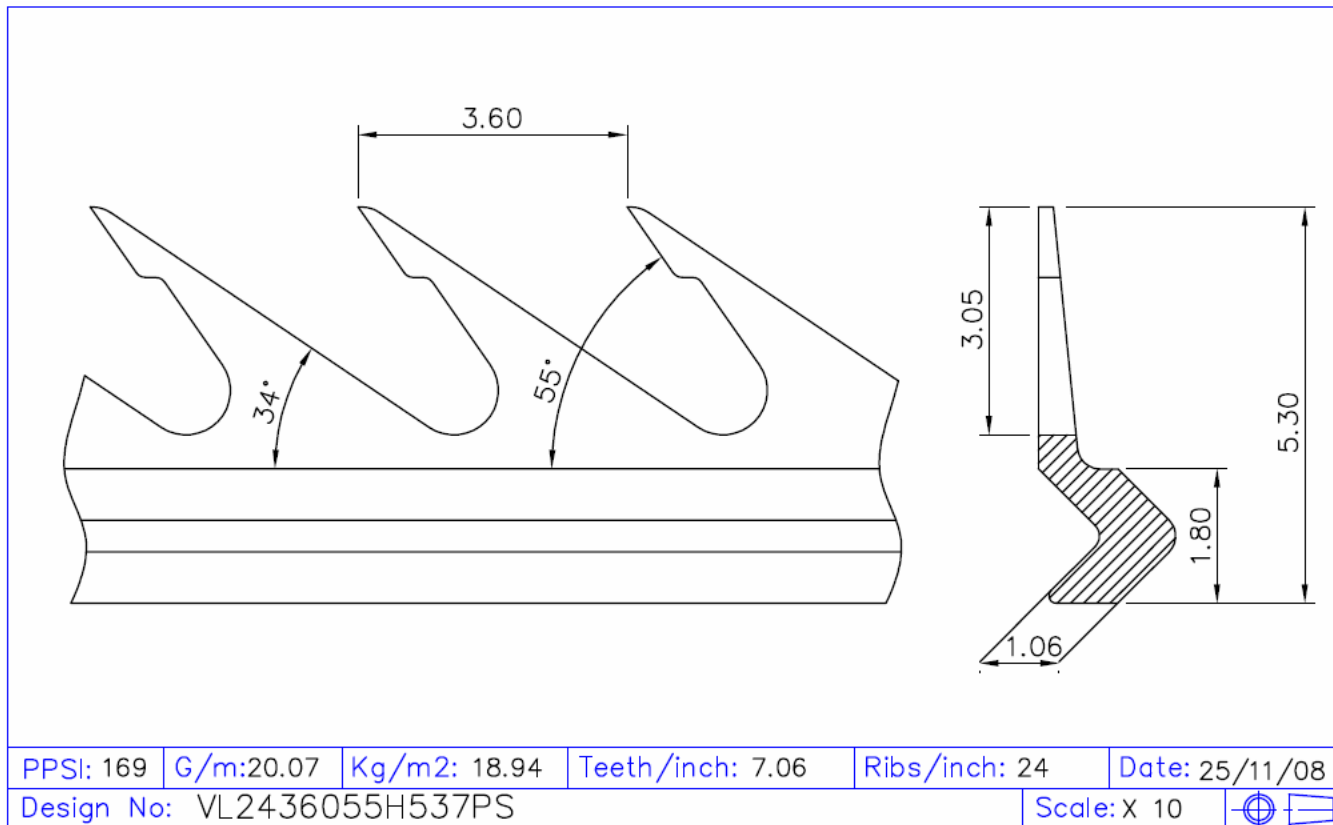

- VL24/360/55 SiroLock®
 - For use in nonwovens

4. SiroLock® wire types

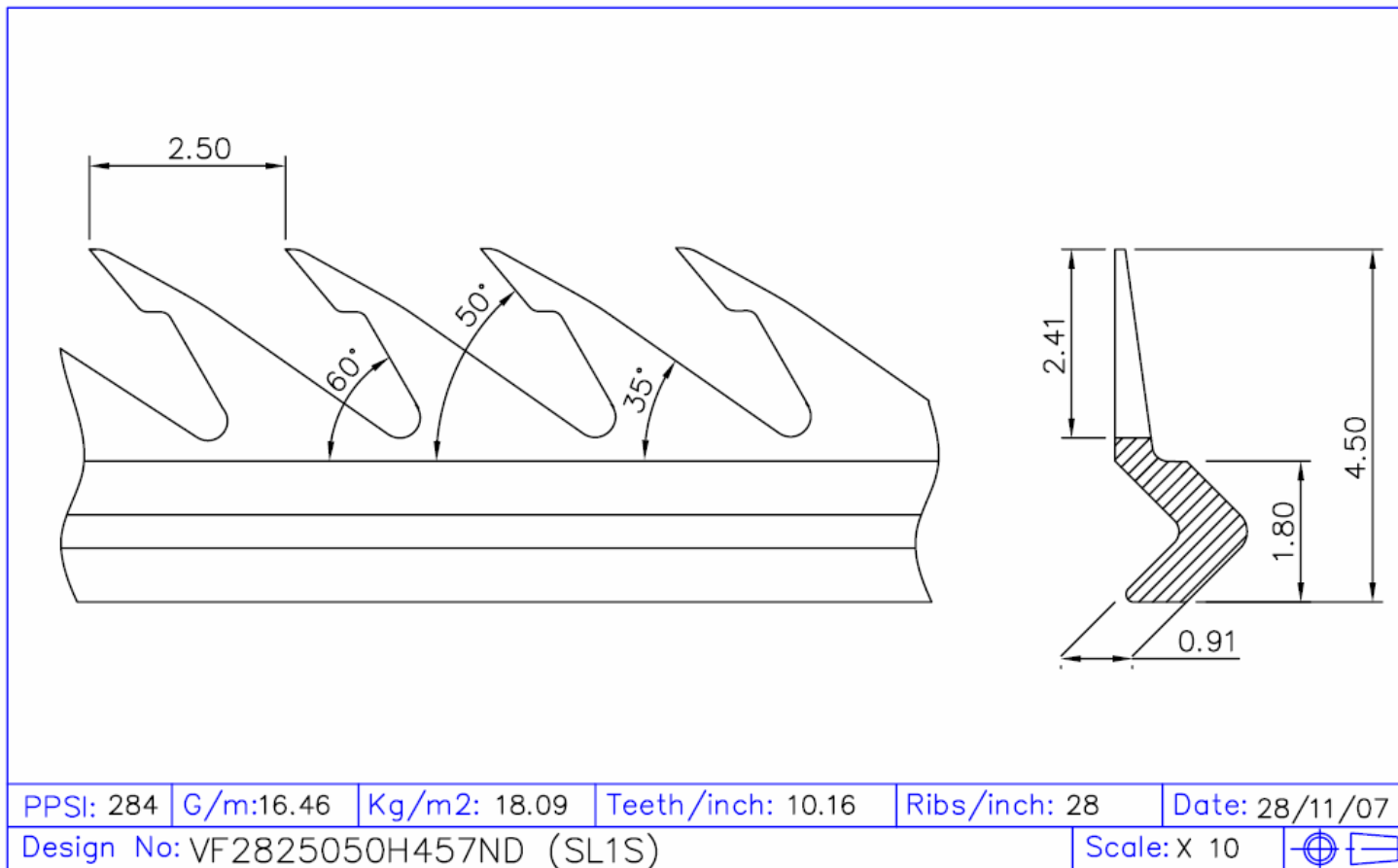

- VF28/250/50 SiroLock® for light weight webs
 - Is the SiroLock® version of VF28/250/50 (previously D28A/4527)

BEKAERT

better together

5. Industry related benefits – worsted industry

Worsted industry (top making)

- Reduced fibre recycling on the cylinder
 - Reduced nep formation
 - Less fibre breakage – less fibre shortening
 - Improved Hauteur (average fibre length)
 - Reduced noil – higher fibre efficiency
- Possibility to raise production for a same quality (for same Hauteur)

Value for customers:

- immediate payback through quality – raw material savings – increased production

5. Industry related benefits – woollen industry

Woollen industry (carpet yarn, knitting yarn...)

- Potential for increased production
- Improved coefficient of variation on slubbing (less thin and thick places)
 - Reduced yarn breaks in spinning

Value for customers:

- Less downtime in carding and spinning
- Potential for increased production
- Immediate payback through savings

5. Industry related benefits - nonwoven

Nonwoven cards

- Increased production, through
 - increased delivery speed; and/or
 - heavier web weight
 - Improved web uniformity
 - Reduced fibre consumption and waste
 - Reduced nep formation
 - A wider range of web weights with same SiroLock® wire type
-
- Value for customer
 - Higher throughput and/or quality depending on the final use of the web
 - Fast payback through
 - increased output
 - improved and more uniform web quality

Value calculation – payback of SiroLock® wire

See the Excel sheet to calculate the payback of SiroLock for particular operational situations.

6. Conclusion

- SiroLock® wire is a breakthrough in fibre control for all carding applications
 - More fibres are transferred from the cylinder to workers and doffers
- Value for customers through improved productivity and web quality for all applications
 - Worsted industry (top making)
 - Woollen industry
 - Nonwoven industry
- SiroLock® wire for workers and doffers is offering fast payback
- Bekaert is your exclusive partner for SiroLock® wires

Contact

Bekaert is always near to you

Bekaert Carding Solutions N.V.

Bekaertstraat 8
BE-8550 Zwevegem
Belgium

T +32-56 65.19.20

F +32-56 75.42.36

carding.solutions@bekaert.com

www.bekaert.com

 **BEKAERT**

better together

better together